

Flow Control Expert



# Ball Valve

**Forged Steel & Cast Steel  
Trunnion Mounted Ball Valve**





- **General Design**

The ball is fixed by trunnion (size 4" & smaller) or trunnion support (size 6" & larger), and the seat rings are floating, free to move against the ball along the valve centerline. The trunnion / trunnion support together with bearings adsorb the side load created by the pressure acting on the ball. At low pressure, the seat tight sealing is ensured by the preload of the springs acting on the seat rings. Along with the pressure increasing, the process medium pressure pushes the seat rings against the ball to provide additional load for tight sealing.

The ball and stem are independent with each other to minimize the effect of the side thrust generated by the pressure acting on the ball.

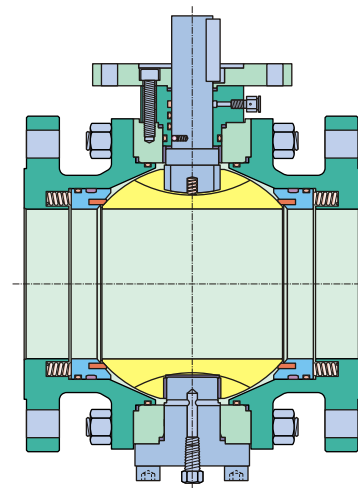

TF 4" &amp; Smaller

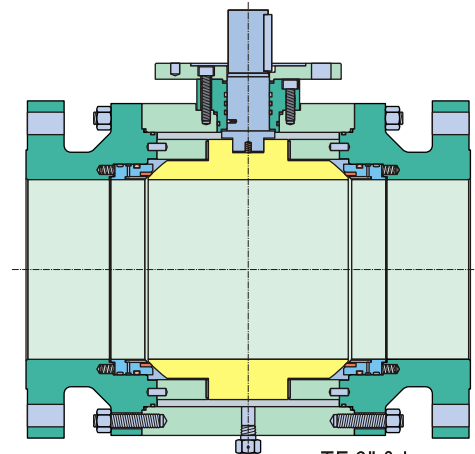

TF 6" &amp; Larger

- **Ball Seat Alignment**

Mechanical stops are equipped on all valves to ensure the ball is never to be over rotated.

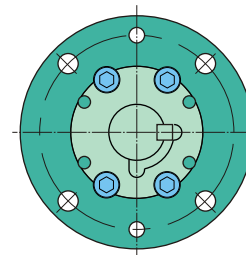

- **AED O-Ring**

When valves are used under high pressure gas applications, e.g. hydrocarbon gas service under class 600 and above, the gas may be absorbed into the molecular structure of elastomeric O-rings. If the valve is subjected to sudden decompression, the O-rings may be destroyed by the rapidly expanded gas. To avoid this possibility, special AED O-rings or Lip seals, suitable for such service conditions, are available on request.

- **Environment Friendly Valve**

Accurate machining of stem, gland and body sealing surfaces with double sealing (O-ring primary seal plus graphite gasket seal) ensure the low emission which is complying with the most severe pollution-control regulations. The test certifications are available on request.



### • Seat Design

Standard seat design is primary soft seal, and secondary metal to metal seal. Seat insert is designed as pressed-in type which is easy for maintenance. (Fig. 1) Optional design with primary metal to metal seal and secondary soft seal seat design is also available upon request. (Fig. 2)

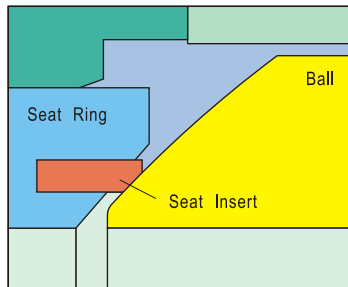

Fig.1

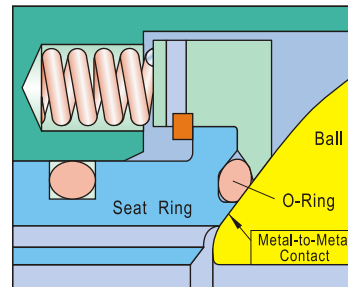

Fig.2

#### a) Standard: Single Piston Effect Seats (Self Relieving Seats)

Medium pressure, both upstream and downstream, creates a resultant thrust to the seat rings against the ball to assure tight sealing; Medium pressure acting in the body cavity creates a resultant thrust to push the seat rings away from the ball.

The single piston design permits the automatic release of any over pressure in the body cavity when the valve is in the fully open or fully closed position. (Fig. 3, 4)

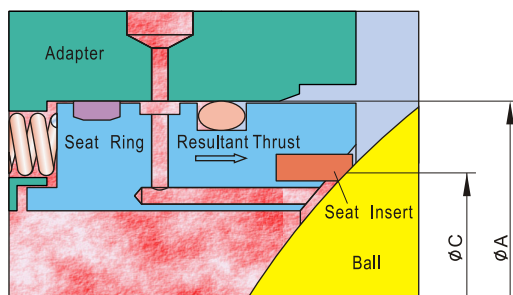

Fig.3

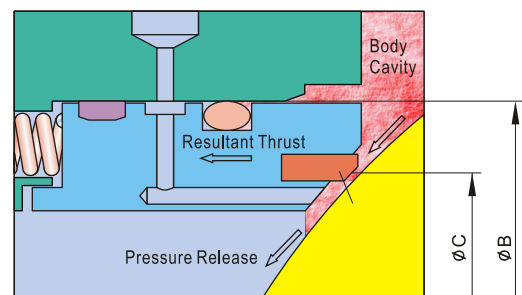

Fig.4

#### b) Option 1: Double Piston Effect Seats

Medium pressure, both upstream and downstream as well as in the body cavity, creates a resultant thrust that pushes the seat rings against the ball. Valves with double piston effect seat rings require a cavity pressure relief device to reduce the build-up of over pressure in the body cavity. (Fig. 5, 6)

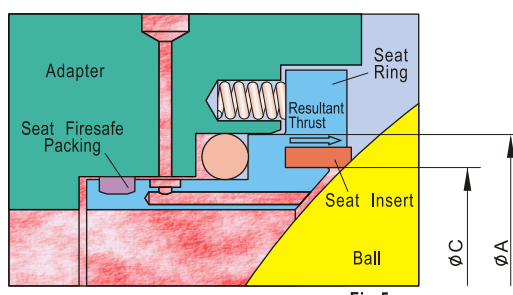

Fig.5

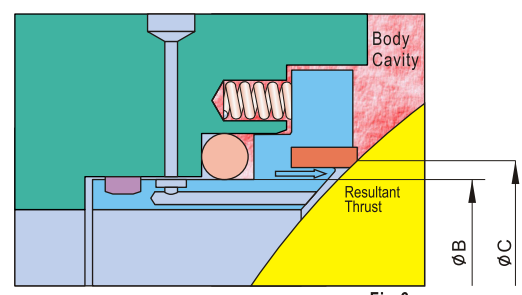

Fig.6

#### c) Option 2: Combination Seats

Combination seats design is available on request. That is a standard seat design used for upstream side and a double piston effect seats design used for downstream. The advantage is it can reach double piston effect seats design function without cavity pressure relief device to saves the cost, meanwhile only need a little care to install valve per flow direction arrow. (Fig. 3, 6)



- **Double Block and Bleed**

When the ball is in the closed position, each seat seals off the process medium independently at the same time between the up/down stream and body cavity; it allows bleeding of the trapped cavity pressure (DBB) through drain or vent valve. The double block and bleed function makes it possible to flush the valve under pressure and verify that the seats are sealing properly.(Fig. 7)

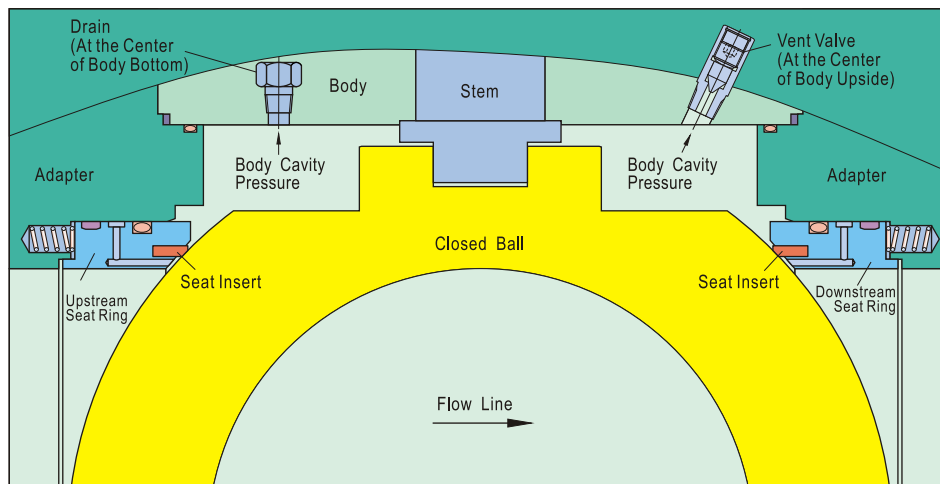

Fig.7

- **Blow-out Proof Stem**

The stem is made separately from the ball with integral T-type round shoulder, retained by gland. (other designs are available on request).(Fig. 8)

- **Anti-static Device**

Spring plus graphite type anti-static device are applied between the ball, stem, gland flange and body, to keep the electrical continuity between all the metallic components, and ensure the resistance lower than the most severe service requirement.(Fig. 8)

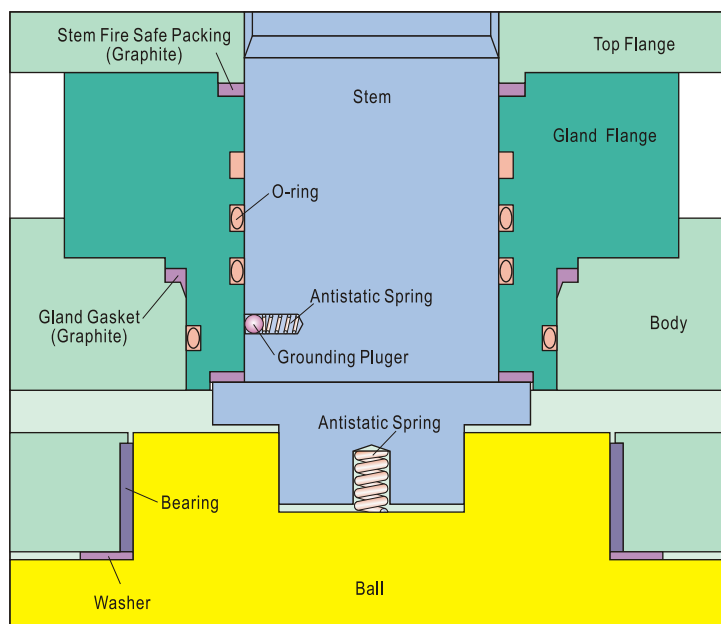

Fig.8



## • Fire Safe

### a) External leakage prevention

All the possible external leakage point between stem and gland flange, gland flange and body, body and adapter are sealed with primary O-ring then secondary graphite gasket. When fire burned out the primary O-ring seal, the secondary graphite gasket seal still can prevent the process medium from external leakage.(Fig. 9)

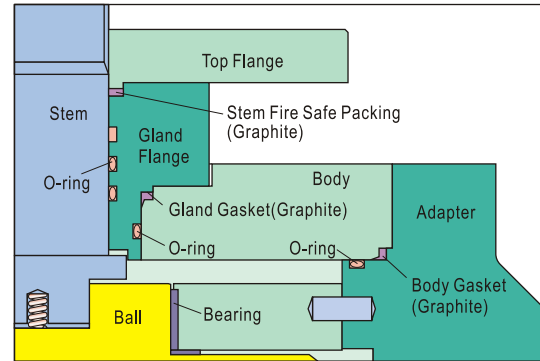

Fig.9

### b) Internal leakage prevention

When fire burned out the primary O-ring seal between the floating seat ring and adapter, also the seat insert between seat ring and ball, the secondary graphite seal between seat ring and adapter, and seat ring & ball metal to metal contact preloaded by spring will minimize the internal process medium leakage. (Fig. 10, 11)

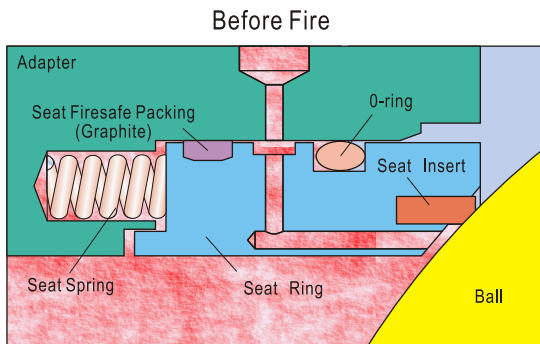

Fig.10

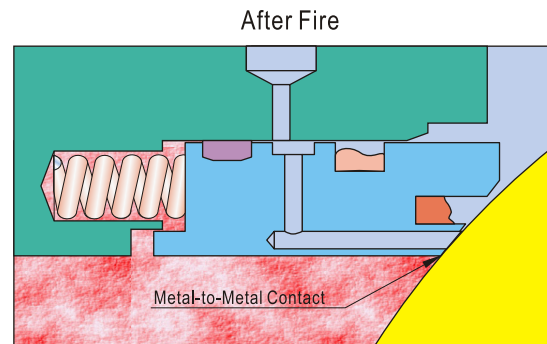

Fig.11

## • Emergency Sealant Injection System

Each valve of size 6" and larger (or smaller size on request), is equipped with sealant injection located at stem and seats area. The injection is integrated with check valve to provide backup sealing, also a check valve is equipped at front of seat sealant injection to avoid blowing out in case wrong operation. When the soft sealing materials (seat inserts and o-rings) are damaged and leakage happened by fire or other accident, the sealant can be injected through the injection fittings.(Fig. 12)

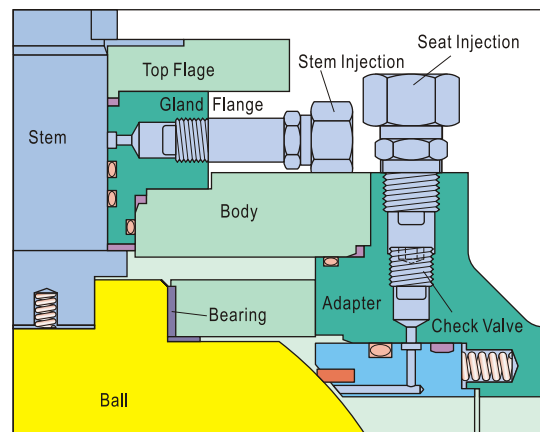
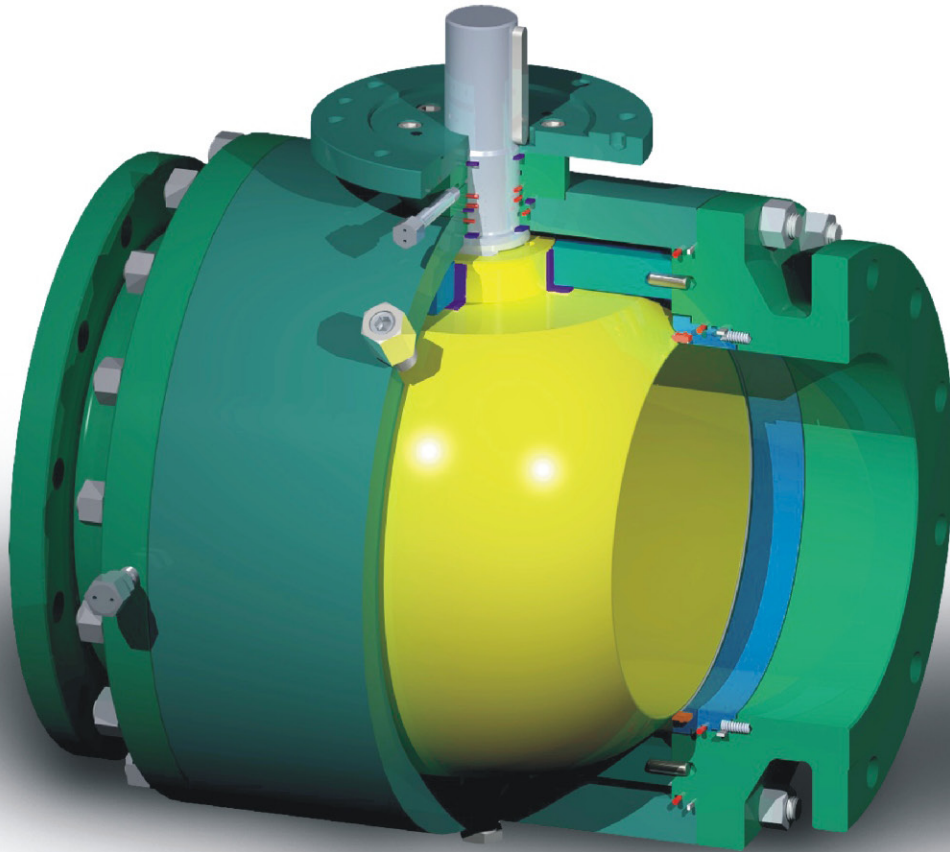

Fig.12



### Features

Size: 2"~48"
Class: 150~2500
Three Pieces Forged Steel Body
Trunnion Mounted Ball, Full & Reduced Bore
Anti-Static Device
Blow-out Proof Stem
Double Block and Bleed
Fire Safe Design
Emergency Sealant Injector ( 6" & Larger)
Vent Valve ( 6" & Larger)
Lifting Lugs & Supporting Feet ( 8" & Larger)

### Specifications

Design	ASME B16.34/API 6D
Face to Face	ASME B16.10/API 6D
End to End	ASME B16.10/API 6D
End Flange	ASME B16.5/B16.47 A
BW End	ASME B16.25
Test	API 6D
Fire Safe Test	API 607/API 6FA
Special	NACE MR 01 75
	Seat Pocket SS Overlay(Optional)
	Seals Area ENP Coated



# 3PC Body Forged Trunnion Mounted Ball Valve Series TF

Series TF

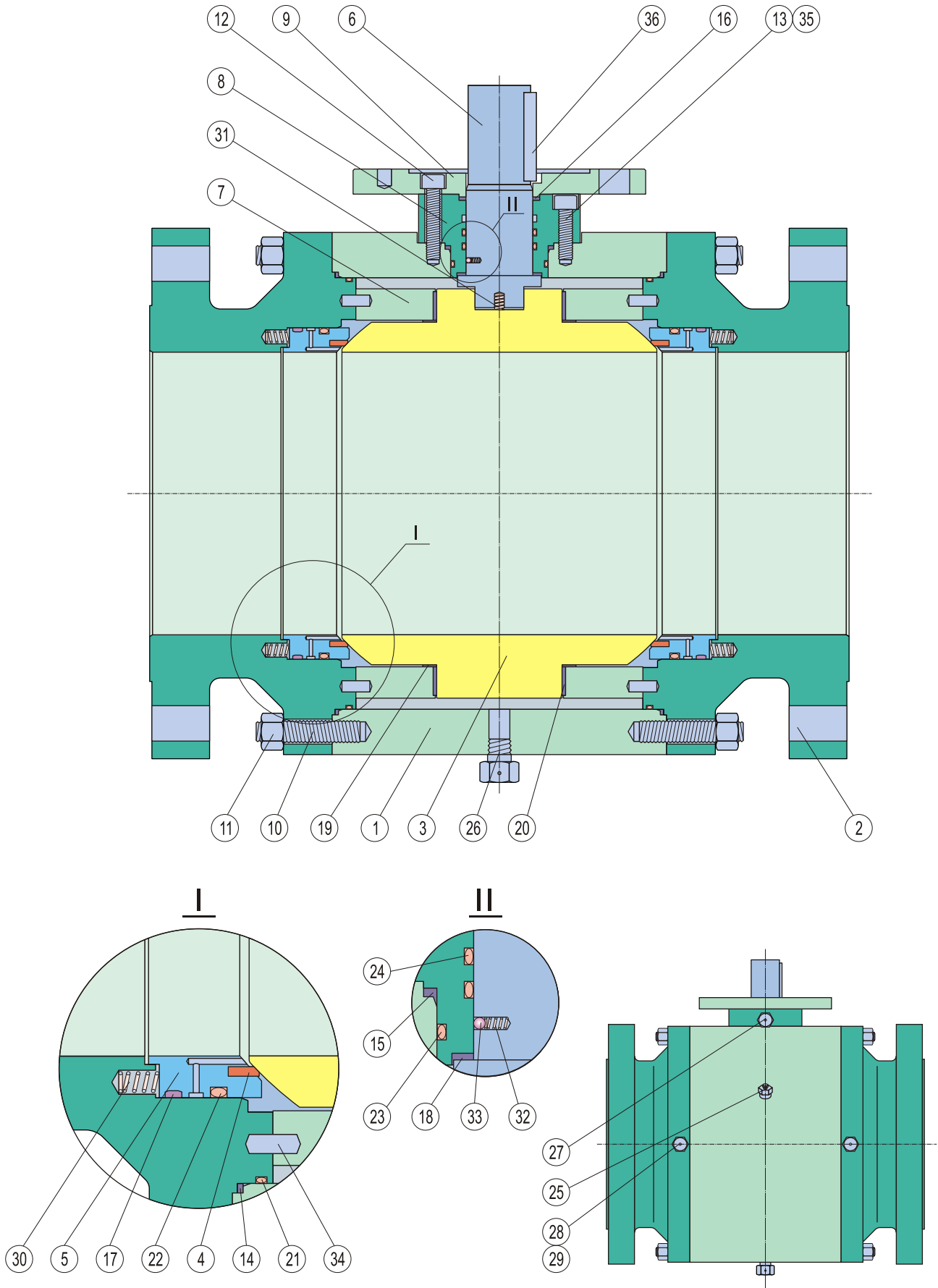



## Material Specifications

No.	Part	A105/ENP	A105/316	F316/316	LF2/316 NACE
1	Body	ASTM A105N	ASTM A105N	ASTM A182-F316	ASTM A350-LF2
2	Adapter	ASTM A105N	ASTM A105N	ASTM A182-F316	ASTM A350-LF2
3	Ball	ASTM A105N/ENP	ASTM A182-F316	ASTM A182-F316	ASTM A182-F316
4	Seat Insert	PTFE/Nylon/PEEK	PTFE/Nylon/PEEK	PTFE/Nylon/PEEK	PTFE/Nylon/PEEK
5	Seat Ring	ASTM A105N/ENP	ASTM A182-F316	ASTM A182-F316	ASTM A182-F316
6	Stem	AISI 4140/ENP	ASTM A182-F51	ASTM A182-F51	ASTM A182-F51
7	Trunnion Support	ASTM A105N/ENP	ASTM A105N/ENP	ASTM A182-F316	ASTM A350-LF2/ENP
8	Gland Flange	ASTM A105N/ENP	ASTM A105N/ENP	ASTM A182-F316	ASTM A350-LF2/ENP
9	Top Flange	ASTM A105N	ASTM A105N	ASTM A182-F316	ASTM A350-LF2
10	Body Stud	ASTM A193-B7	ASTM A193-B7	ASTM A193-B8	ASTM A320-L7M
11	Body Nut	ASTM A194-2H	ASTM A194-2H	ASTM A194-8	ASTM A194-7M
12	Screw	Carbon Steel	Carbon Steel	Stainless Steel	ASTM A320-L7M
13	Screw	Carbon Steel	Carbon Steel	Stainless Steel	ASTM A320-L7M
14 *	Body Gasket	Graphite	Graphite	Graphite	Graphite
15 *	Gland Gasket	Graphite	Graphite	Graphite	Graphite
16 *	Stem Firesafe Packing	Graphite	Graphite	Graphite	Graphite
17 *	Seat Firesafe Packing	Carbon Fibre+Graphite	Carbon Fibre+Graphite	Carbon Fibre+Graphite	Carbon Fibre+Graphite
18	Thrust Washer	PTFE/316SS+PTFE+MoS2	PTFE/316SS+PTFE+MoS2	PTFE/316SS+PTFE+MoS2	PTFE/316SS+PTFE+MoS2
19	Washer	PTFE/316SS+PTFE+MoS2	PTFE/316SS+PTFE+MoS2	PTFE/316SS+PTFE+MoS2	PTFE/316SS+PTFE+MoS2
20	Bearing	316SS+PTFE+MoS2	316SS+PTFE+MoS2	316SS+PTFE+MoS2	316SS+PTFE+MoS2
21 *	O-Ring	Viton	Viton	Viton	Viton
22 *	O-Ring	Viton	Viton	Viton	Viton
23 *	O-Ring	Viton	Viton	Viton	Viton
24 *	O-Ring	Viton	Viton	Viton	Viton
25	Vent Valve	Stainless Steel	Stainless Steel	Stainless Steel	Stainless Steel
26	Drain	Stainless Steel	Stainless Steel	Stainless Steel	Stainless Steel
27	Stem Injection	Stainless Steel	Stainless Steel	Stainless Steel	Stainless Steel
28	Seat Injection	Stainless Steel	Stainless Steel	Stainless Steel	Stainless Steel
29	Check Valve	Stainless Steel	Stainless Steel	Stainless Steel	Stainless Steel
30	Seat Spring	INCONEL X-750	INCONEL X-750	INCONEL X-750	INCONEL X-750
31	Antistatic Spring	INCONEL X-750	INCONEL X-750	INCONEL X-750	INCONEL X-750
32	Antistatic Spring	INCONEL X-750	INCONEL X-750	INCONEL X-750	INCONEL X-750
33	Grounding Plunger	Stainless Steel	Stainless Steel	Stainless Steel	Stainless Steel
34	Alignment Pin	Stainless Steel	Stainless Steel	Stainless Steel	Stainless Steel
35	Gland Pin	Carbon Steel	Carbon Steel	Stainless Steel	Carbon Steel
36	Key	Carbon Steel	Carbon Steel	Stainless Steel	Carbon Steel

\* Recommended Spare Parts





### Dimensions and Weights

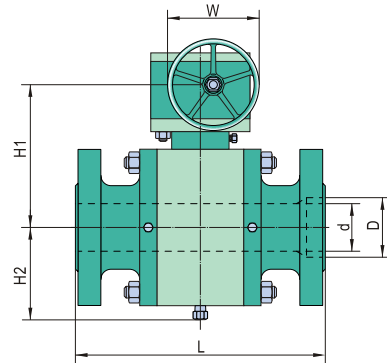
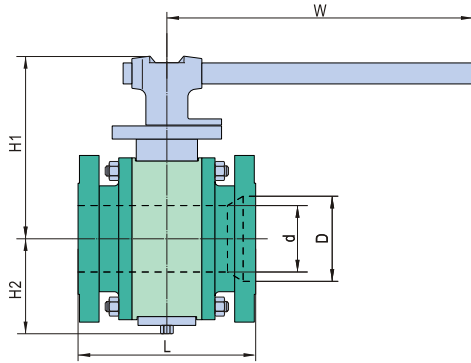

#### Full Bore

#### Class 150

Size	d	L	H1	H2	W	Weight
in	mm	mm	mm	mm	mm	Kg
2	51	178	155	85	350	30
3	76	203	191	110	400	60
4	102	229	211	130	450	92
6	152	394	231	160	*305	190
8	203	457	282	235	*406	345
10	254	533	336	290	*406	495
12	305	610	373	315	*406	705
14	337	686	413	345	*406	859
16	387	762	457	383	*600	1020
18	438	864	501	435	*600	1440
20	489	914	551	495	*600	1918
22	540	991	600	555	*600	2352
24	591	1067	635	590	*700	2803
26	635	1143	710	620	*700	3200
28	686	1245	760	670	*760	4045
30	737	1295	800	710	*760	4820
32	781	1372	840	745	*760	5490
34	832	1473	890	775	*760	6704
36	876	1524	930	805	*760	7615
40	978	1727	1010	900	*760	10271
42	1022	1987	1598	900	*760	12200
48	1168	2120	1722	1040	*760	18400

#### Reduced Bore

#### Class 150

Size	d	D	L	H1	H2	W	Weight
in	mm	mm	mm	mm	mm	mm	Kg
2*1-1/2	38	51	178	152	80	350	26
3*2	51	76	203	155	85	350	34
4*3	76	102	229	191	110	400	62
6*4	102	152	394	211	130	450	102
8*6	152	203	457	231	160	*305	225
10*8	203	254	533	282	235	*406	373
12*10	254	305	610	336	290	*406	533
14*10	254	337	686	336	290	*406	626
14*12	305	337	686	373	315	*406	730
16*12	305	387	762	373	315	*406	790
16*14	337	387	762	413	345	*406	844
18*14	337	438	864	413	345	*406	1010
18*16	387	438	864	457	383	*600	1095
20*16	387	489	914	457	383	*600	1115
20*18	438	489	914	501	435	*600	1152
22*18	438	540	991	501	435	*600	2343
24*20	489	591	1067	551	495	*600	2060
26*22	540	635	1143	600	555	*600	2215
28*24	591	686	1245	635	590	*700	2803
30*24	591	737	1295	635	590	*700	2803
32*26	635	781	1372	710	620	*700	4005
34*28	686	832	1473	760	670	*760	4445
36*30	737	876	1524	820	710	*760	4995
40*34	832	978	1727	935	775	*760	8200

#### Full Bore

#### Class 300

Size	d	L	H1	H2	W	Weight
in	mm	mm	mm	mm	mm	Kg
2	51	216	155	85	400	31
3	76	283	191	110	450	69
4	102	305	211	130	500	110
6	152	403	229	160	*305	211
8	203	502	291	235	*406	376
10	254	568	340	290	*406	540
12	305	648	375	315	*500	763
14	337	762	417	345	*600	900
16	387	838	466	400	*600	1300
18	438	914	506	440	*600	1715
20	489	991	563	495	*600	2090
22	540	1092	605	560	*700	2220
24	591	1143	684	590	*760	2890
28	686	1346	770	680	*760	4575
30	737	1397	810	720	*760	5590
32	781	1524	850	760	*800	6240
34	832	1626	900	790	*800	7370
36	876	1727	940	820	*800	8435
40	978	1956	1025	915	*800	11200
42	1022	2032	1640	920	*800	13000
48	1168	2170	1765	1070	*800	19000

#### Reduced Bore

#### Class 300

Size	d	D	L	H1	H2	W	Weight
in	mm	mm	mm	mm	mm	mm	Kg
2*1-1/2	38	51	216	152	80	350	30
3*2	51	76	283	155	85	400	37
4*3	76	102	305	191	110	450	74
6*4	102	152	403	211	130	500	142
8*6	152	203	502	229	160	*305	253
10*8	203	254	568	291	235	*406	410
12*10	254	305	648	340	290	*406	580
14*10	254	337	762	340	315	*406	683
14*12	305	337	762	375	315	*500	830
16*12	305	387	838	375	360	*500	1051
16*14	337	387	838	417	360	*600	1125
18*14	337	438	914	417	400	*600	1320
18*16	387	438	914	466	400	*600	1530
20*16	387	489	991	466	420	*600	1780
20*18	438	489	991	506	440	*600	1830
22*18	438	540	1092	506	440	*600	2010
24*20	489	591	1143	563	495	*600	2220
28*24	591	686	1346	684	590	*760	3200
30*24	591	737	1397	684	590	*760	3200
34*28	686	832	1626	770	680	*760	4845
36*30	737	876	1727	810	720	*760	5590
40*34	832	978	1956	900	790	*800	8200

\* Gear Operated



# Series TF 3PC Body Forged Trunnion Mounted Ball Valve

## Dimensions and Weights

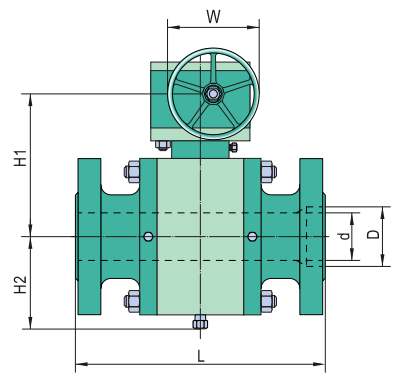
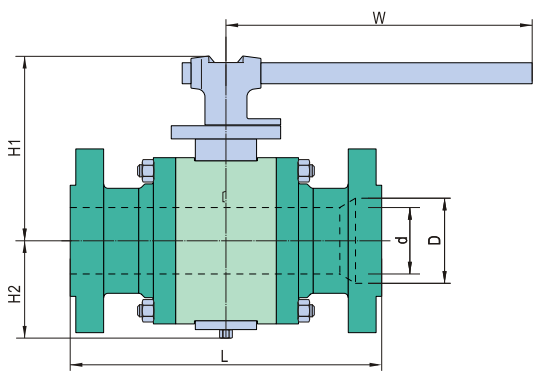

Full Bore		Class 600				
Size	d	L	H1	H2	W	Weight
in	mm	mm	mm	mm	mm	Kg
2	51	292	155	85	400	45
3	76	356	193	112	500	80
4	102	432	239	140	700	150
6	152	559	266	175	*406	248
8	203	660	310	250	*406	438
10	254	787	354	290	*600	701
12	305	838	411	345	*600	855
14	337	889	435	370	*600	1230
16	387	991	493	420	*600	1535
18	438	1092	544	462	*700	2135
20	489	1194	629	515	*760	2640
22	540	1295	683	570	*800	3370
24	591	1397	728	610	*800	3960
28	686	1549	810	695	*800	6060
30	737	1651	863	735	*800	6690
32	781	1778	900	775	*800	7825
34	832	1930	940	820	*800	8460
36	876	2083	990	885	*800	10650
40	978	2159	1070	935	*800	14700
42	1022	2175	1640	940	*800	16400
48	1168	2435	1765	1070	*800	24200

Reduced Bore		Class 600					
Size	d	D	L	H1	H2	W	Weight
in	mm	mm	mm	mm	mm	mm	Kg
2*1-1/2	38	51	292	152	80	350	40
3*2	51	76	356	155	85	400	54
4*3	76	102	432	193	112	500	99
6*4	102	152	559	239	140	700	212
8*6	152	203	660	266	175	*406	304
10*8	203	254	787	310	250	*406	510
12*10	254	305	838	354	290	*600	794
14*10	254	337	889	354	345	*600	843
14*12	305	337	889	411	345	*600	910
16*12	305	387	991	411	370	*600	965
16*14	337	387	991	435	370	*600	1310
18*14	337	438	1092	435	410	*600	1520
18*16	387	438	1092	493	420	*600	1640
20*16	387	489	1194	493	440	*600	2065
20*18	438	489	1194	544	462	*700	2270
22*18	438	540	1295	544	462	*700	2430
24*20	489	591	1397	629	515	*760	3440
28*24	591	686	1549	728	610	*800	4250
30*24	591	737	1651	728	610	*800	4730
34*28	686	832	1930	810	695	*800	7200
36*30	737	876	2083	863	735	*800	8600
40*34	832	978	2159	940	820	*800	10020

Full Bore		Class 900LB				
Size	d	L	H1	H2	W	Weight
in	mm	mm	mm	mm	mm	Kg
2	51	368	178	100	450	52
3	76	381	221	125	600	87
4	102	457	215	150	*305	160
6	152	610	268	215	*406	385
8	203	737	324	260	*600	560
10	254	838	371	305	*600	820
12	305	965	425	360	*600	1125
14	324	1029	463	390	*600	1610
16	375	1130	513	440	*710	2010
18	425	1219	614	500	*760	2810
20	473	1321	644	530	*760	3460
24	572	1549	745	630	*800	5497
28	667	1753	830	720	*800	10202
30	714	1880	880	755	*800	11442
34	810	2159	970	850	*900	17462
36	857	2286	1030	930	*900	20154

Reduced Bore		Class 900LB					
Size	d	D	L	H1	H2	W	Weight
in	mm	mm	mm	mm	mm	mm	Kg
2*1-1/2	38	51	368	152	80	400	45
3*2	51	76	381	178	100	450	56
4*3	76	102	457	221	125	600	94
6*4	102	152	610	215	150	*305	226
8*6	152	203	737	268	260	*406	480
10*8	203	254	838	324	305	*600	650
12*10	254	305	965	371	335	*600	868
14*10	254	324	1029	371	360	*600	1050
14*12	305	324	1029	425	360	*600	1310
16*12	305	375	1130	425	390	*600	1385
16*14	324	375	1130	463	390	*600	1830
18*16	375	425	1219	513	440	*710	2205
20*16	375	473	1321	513	470	*710	2735
20*18	425	473	1321	614	500	*760	3140
24*20	473	572	1549	644	550	*760	3810
28*24	572	667	1753	745	630	*800	7580
30*24	572	714	1880	745	665	*800	7981
34*28	667	810	2159	830	750	*800	11202
36*30	714	857	2286	880	780	*800	15653

\* Gear Operated



### Dimensions and Weights

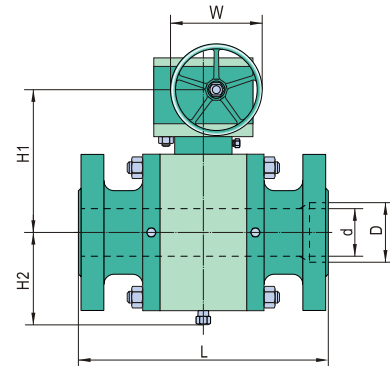
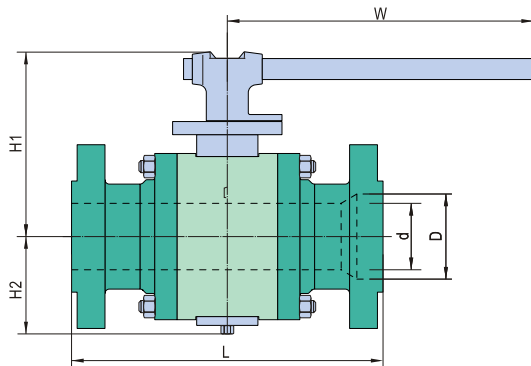

Full Bore Class 1500

Size	d	L	H1	H2	W	Weight
in	mm	mm	mm	mm	mm	Kg
2	51	368	178	100	450	60
3	76	470	226	130	700	115
4	102	546	241	162	*406	194
6	146	705	319	255	*600	580
8	194	832	345	280	*600	752
10	241	991	411	345	*600	1195
12	289	1130	478	405	*600	1970
14	318	1257	517	435	*700	2250
16	362	1384	599	485	*760	2760
18	407	1537	663	545	*800	3646
20	457	1664	695	580	*800	4497
24	548	2045	842	730	*900	7151

Reduced Bore Class 1500

Size	d	D	L	H1	H2	W	Weight
in	mm	mm	mm	mm	mm	mm	Kg
2*1-1/2	38	51	368	152	80	400	56
3*2	51	76	470	178	100	450	82
4*3	76	102	546	226	130	700	150
6*4	102	146	705	241	162	*406	295
8*6	146	194	832	319	270	*600	690
10*8	194	241	991	345	325	*600	930
12*10	241	289	1130	411	370	*600	1340
14*10	241	318	1257	411	405	*600	1840
14*12	289	318	1257	478	405	*600	2070
16*12	289	362	1384	478	435	*600	2520
16*14	318	362	1384	517	435	*700	2670
18*16	362	407	1537	599	485	*760	2950
20*16	362	457	1664	599	545	*760	3825
20*18	407	457	1664	663	545	*800	4150
24*20	457	548	2045	695	640	*800	5850

Full Bore Class 2500

Size	d	L(RTJ)	H1	H2	W	Weight
in	mm	mm	mm	mm	mm	Kg
2	44	454	214	118	700	90
3	64	584	216	150	*406	200
4	89	683	265	180	*406	385
6	133	927	371	305	*600	778
8	181	1038	426	360	*600	1352
10	225	1292	463	390	*710	2137
12	267	1445	550	465	*760	3267

Reduced Bore Class 2500

Size	d	D	L(RTJ)	H1	H2	W	Weight
in	mm	mm	mm	mm	mm	mm	Kg
2*1-1/2	38	44	454	175	95	450	80
3*2	44	64	584	214	118	700	160
4*3	64	89	683	216	150	*406	320
6*4	89	133	927	265	270	*406	640
8*6	133	181	1038	371	305	*600	1170
10*8	181	225	1292	426	370	*600	1919
12*10	225	267	1445	463	415	*710	2972

\* Gear Operated



## DISTRIBUIDOR AUTORIZADO



Carrera 28 N ° 11-65  
Oficina 802  
Bogotá, Colombia



(57) (1) 749 56 26



[www.veincol.com](http://www.veincol.com)  
[info@veincol.com](mailto:info@veincol.com)  
[ventas@veincol.com](mailto:ventas@veincol.com)



(57) 315 370 69 40  
(57) 315 371 06 91